

## 1.000 - 3.000 l/h

### Typical applications

- Ideal for clean or slightly contaminated acids and alkalines
- Suitable for most plating solutions
- Not suitable for electroless nickel and abrasive solutions or solutions which contain ferrous particles

### Features

- Magnetic drive
- Sealless, therefore leakfree
- Provide extra safety factor for aggressive and expensive liquids
- Standard with GF union connections with a choice of sockets, available in PP, PVDF and CPVC
- Max. temp. PP 80°C / 176°F, PVDF 100°C / 212°F
- Motor with two component Polyurethane coating for excellent chemical resistance

### Options

- Hose adapters

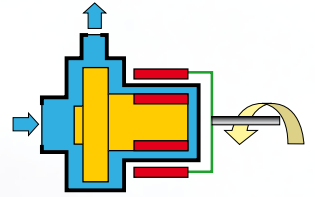

M10

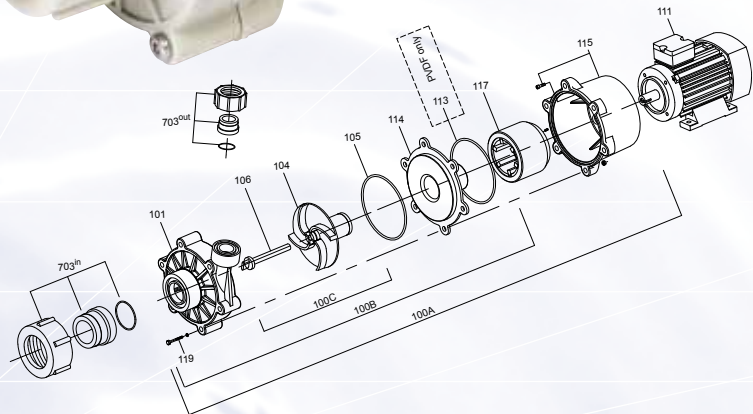
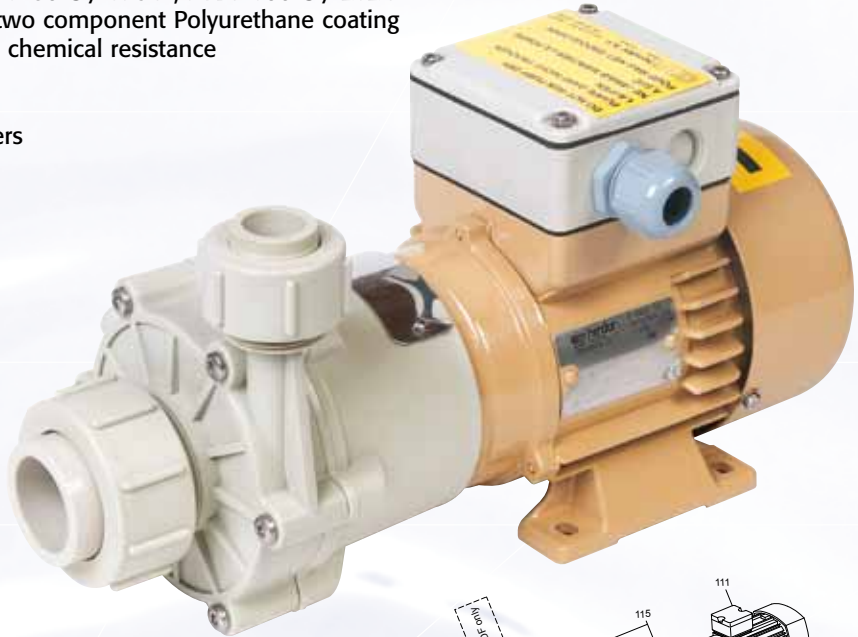

## Magnetic drive pumps M10/11/15 - PP/PVDF

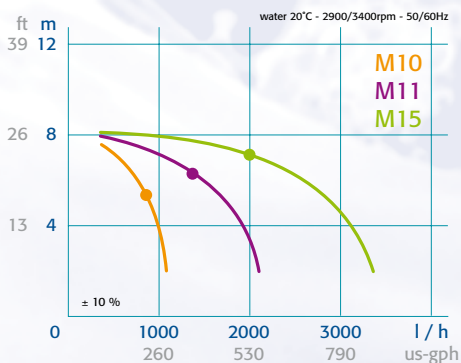

Type	Motor kW	Motor HP	Max SG at BEP	Net weight kg	In d/DN	Out d/DN
M10			1,25			
M11	0,18*	1/4*	1,22	5	32/25	20/15
M15			1,19			

\* For 3-phase motors < 220V the indicated motor will be 0,25kW = 1/3HP  
d/DN = OD/ID metric size pipe

Best Efficiency Point (BEP)

[www.hendor.com](http://www.hendor.com)

